

Research on valve core's clamping stagnation of double flapper-nozzle servo valve^①

Zhao Jianhua(赵建华)^②, Zhang Bin, Chen Tao, Wang Qiang, Zhou Songlin, Gao Dianrong
(Hebei Provincial Key Laboratory of Heavy Machinery Fluid Power Transmission and Control,
Yanshan University, Qinhuangdao 066004, P. R. China)

Abstract

Due to great changing of instantaneous temperature of hydraulic oil of double flapper-nozzle servo valve, thermal deformation between valve core and valve sleeve may result in catching phenomenon of valve core, and then the reliability of servo valve could be affected seriously. The work focuses on a particular model of double flapper-nozzle servo valve and establishes three dimension couple models of liquid-solid-thermal under extreme operating condition. The transmission route and dissipative mechanism of heat is revealed and thermal deformation behavior of valve core and valve sleeve is researched. A change law of the key fit clearance under the effect of thermal expansion and warp deformation is explored, the source of catching phenomenon of valve core is identified, and then preventive measure and improvement can be proposed. In order to verify the correctness of theoretical analysis, the moving smoothness of deformed valve core and reground valve core under the circumstance of high-temperature hydraulic oil on electrohydraulic servo valve static characteristics test table is compared and tested. The results show that as oil temperature rises, relative deformations between valve core and valve sleeve in different direction at a same cross-section are not equal, and then the key fit clearance is less than the initial value. Relative deformations in the same direction at different axial position are not equal, the deformations of middle and two ends are maximum and minimum values respectively, and then warp deformation of valve core occurs. When oil temperature is higher, the relative deformations between valve core and valve sleeve is larger, the moving smoothness of valve core gets worse, and the catching phenomenon of valve core occurs. Axial deformation of valve sleeve and valve core at different axial position is different, and the opening coefficient and stability of servo valve could be affected, especially the operation circumstance of small opening. The study can provide some guidance for designing double nozzle flapper servo valves.

Key words: double flapper-nozzle servo valve, flow-solid-thermal coupling numerical simulation, catching phenomenon, thermal deformation mechanism, smooth movement

0 Introduction

Due to good linearity and dynamic characteristics^[1,2], double flapper-nozzle servo valve is mainly used for launch and guidance of equipment.

In special working condition, the system flow soars quickly to the maximum peak. And then the heat is serious and the oil temperature rises up instantly to 80 °C. Due to narrow installation space, heat is not easy to dissipate, and then temperature of shell, valve core and valve sleeve produce a large rise. Movement patency of the valve core is obstructed and catching

phenomenon appears. The working reliability of servo valve and the launch guidance system would be affected greatly^[3].

Many experts and scholars have researched deeply on double flapper-nozzle servo valve and got achievement. By experimental investigations, Halder et al.^[4] recognized the phenomenon of initiation of air core in a simplex type swirl spray pressure nozzle and determined the influences of nozzle geometry and nozzle flow on the size of the fully developed air core. Sirouspour and Salcudean^[5] studied the control problem of a hydraulic servo-system. The performance achievable by classical linear controllers, e. g. PD, is usually limited

① Supported by the National Natural Science Foundation of China (No. 51705445), Natural Science Foundation of Hebei Province of China (No. E2016203324) and Open Foundation of the State Key Laboratory of Fluid Power and Mechatronic Systems.

② To whom correspondence should be addressed. E-mail: zhaojianhua@ysu.edu.cn
Received on Jan. 3, 2018

due to the highly nonlinear behavior of the hydraulic dynamics. Krivts^[6] developed a new flapper-nozzle structure, and studied cavitation phenomenon of the flapper-nozzle. The study obtained the influence of the new flapper-nozzle cavitation position on the cavitation phenomenon of the servo valve. Zhang and Yao^[7] presented a degradation assessment and life prediction method for electro-hydraulic servo valve (EHSV). Mathematic models of turbulent and erosion wear were established by the combined technologies of computational fluid dynamics and erosion theory. By visual simulation, the erosion wear distribution and erosion wear rate under different contaminated oil conditions and working missions were analyzed. Zhang and Luo^[8] studied the cavitation corrosion, spiral vortices, energy loss and temperature rise of the double flapper-nozzle electrohydraulic servo valve by the medium of water, and provided theoretical reference for the optimization of the servo valve pilot valve. Gao and Lu^[9] used the flow field computation software to compute the flow field of the nozzle's different structural parameter combinations, and also analyzed the liquid flow characteristics, as velocity, pressure rate, flow rate, etc. The results showed that the flow rates increased as the diameter, end grinding and external angle of the nozzle increased. Yin et al.^[10] analyzed the flow field of nozzle flapper valve of electro-hydraulic servo valve. The 3D nozzle flapper model of the nozzle flapper was obtained using Solidworks. Meshes were generated using Gambit. The pressure and velocity flow field were obtained by computational fluid dynamics (CFD) software of Fluent. A multi-mesh numerical valve model was developed by Yun et al.^[11] to analyze the opening characteristic of high-pressure safety valves. Newton's law and the CFD result for the flow force were used to model the movement of the valve. In incompressible transient flow simulations, large force rise and collapse are caused by redirection of the bulk flow.

At present, there is no report on the thermal deformation and catching phenomenon of main valve core of double flapper-nozzle servo valve. However, thermal deformation of valve core caused by high temperature is the key factor that affects normal operation of servo valve^[12-14].

For the extreme conditions (oil temperature instantly soared 80 °C) of double flapper-nozzle servo valve of XX company, thermal deformation, movement block and catching phenomenon of valve core and valve sleeve are analyzed in the paper. The flow-solid-thermal coupling model of the servo valve is established, and the heat transfer path and dissipation mechanism are studied. The key fit clearance variation law of valve

core and valve sleeve under the effect of thermal expansion and warping deformation is analyzed. The corresponding prevention and improvement measures are put forward, and theoretical reference for performance improvement and fault diagnosis are provided.

1 Extreme working condition and heat dissipation mechanism of servo valve

1.1 Introduction of structure and extreme working condition

Structure of servo valve double flapper-nozzle servo valve consists of torque motor components, flapper-feedback spring rod components, fixed throttle, nozzle, main valve core, valve sleeve and other key components^[15]. The structure of double flapper-nozzle servo valve is shown in Fig. 1 and Fig. 2.

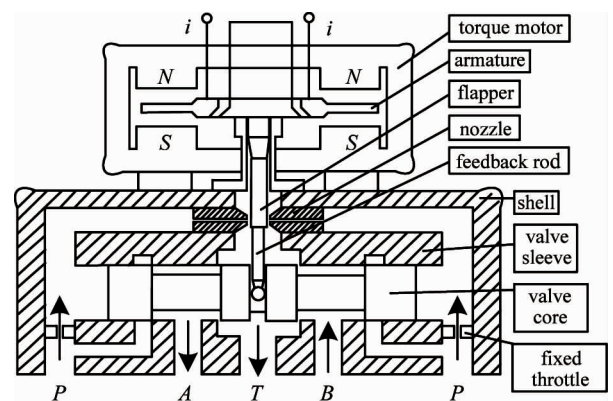

Fig. 1 Structure of double flapper-nozzle servo valve

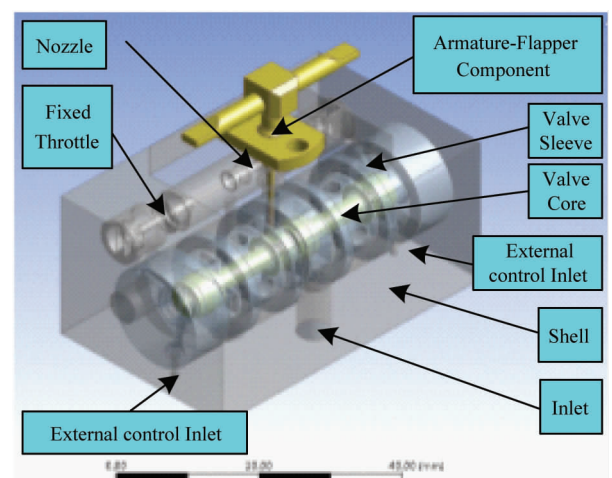

Fig. 2 Three-dimensional model of double flapper-nozzle servo valve

The structural parameters of double flapper nozzle servo valve are shown in Table 1.

Table 1 Parameters of double flapper-nozzle servo valve

| | | | | |
|-----------|---|--|--|---|
| Parameter | Diameter of throttle (mm) | Diameter of nozzle (mm) | Diameter of return oil pole (mm) | Diameter of valve core (mm) |
| Value | 0.21 | 0.45 | 0.45 | 6.40 |
| Parameter | Length of throttle (mm) | Length of nozzle (mm) | Length of valve core (mm) | Density of valve core and sleeve (kg/m^3) |
| Value | 0.25 | 0.70 | 38.80 | 8 030 |
| Parameter | Heat conductivity coefficient of valve core and sleeve ($\text{W}/\text{m} \cdot \text{K}$) | Specific heat of valve core and sleeve ($\text{J}/\text{kg} \cdot \text{K}$) | Density of armature component (kg/m^3) | Specific heat of armature component ($\text{J}/\text{kg} \cdot \text{K}$) |
| Value | 16 | 500 | 9 000 | 381 |
| Parameter | Specific heat of armature component ($\text{W}/\text{m} \cdot \text{K}$) | Pressure of return oil (MPa) | Hydraulic oil | Environment temperature (K) |
| Value | 382 | 0.5 | 10# Aircraft hydraulic oil | 300 |
| Parameter | Coefficient of convection heat transfer ($\text{W}/(\text{m}^2 \cdot \text{K})$) | Pressure of inlet oil (MPa) | Temperature of oil pocket ($^{\circ}\text{C}$) | |
| Value | 30 | 20 | 40 | |

In the process of equipment launching, the oil temperature instantly soared to 120°C due to friction and external environment. Due to high-temperature of the hydraulic oil, shell, valve core and valve sleeve large radial thermal deformation and warping deformation occur. The fit clearance between valve core and valve sleeve has changed severely. The catching phenomenon of valve core appears, and then operation reliability of servo valve is affected severely.

1.2 Heat transfer path and dissipation mechanism of servo valve

During the working process, due to complicated limited installation space, the heat produced by throttle and nozzle is hard to dissipate, and then the hydraulic oil will soar to 120°C instantly.

The heat of the hydraulic oil is difficult to be spread on time. After it flows into the servo valve, hot hydraulic oil exchanges heat with shell, sleeve, and valve core when it flows through main flow path. Finally the temperature of hydraulic oil decreases after it flows out of the servo valve.

The temperature of the valve core and valve sleeve rise gradually after it exchanges heat with hydraulic oil, and then it moves heat to the shell by solid-solid heat conduction. The shell directly contacts and generates heat exchange with the surrounding atmosphere and then the heat can be dissipated, as shown in Fig. 3.

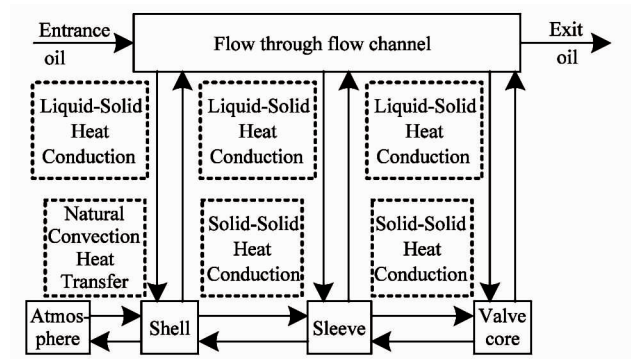

Fig. 3 Heat transfer and dissipation mechanism of servo valve

1.3 Fault tracing of valve core's clamping stagnation

There will be temperature rise and thermal deformation in the valve core and valve sleeve after exchanging heat with the hot hydraulic oil. Due to the difference of temperature between valve core and valve sleeve, the axial and radial thermal deformation between valve core and valve sleeve occurs.

The heat conduction of the high temperature hydraulic oil leads to temperature rise in the valve core and valve sleeve, resulting in thermal deformation; Due to the difference of temperature between valve core and valve sleeve, there is a certain temperature difference, which leads to non-uniformity of thermal deformation in the axial and radial between the valve core and valve sleeve.

The radial deformation of the valve core and valve sleeve is inconsistent, and the fit clearance changes. The movement smoothness of valve core and control accuracy of servo valve can be affected, and the catching phenomenon of valve core appears.

The change of the opening degree of main valve caused by the inconsistent axial deformation of valve core and valve sleeve can lead to control performance of servo valve. The warp deformation of valve core caused by the inconsistent temperature rise and radial thermal deformation of valve core within same cross-section in different radial direction results in catching phenomenon of valve core.

Due to the inconsistent temperature rise of valve core and valve sleeve, catching phenomenon of main valve core is caused by the decreases of radial fit clearance between valve core and valve sleeve and warping deformation of valve core, as shown in Fig. 4.

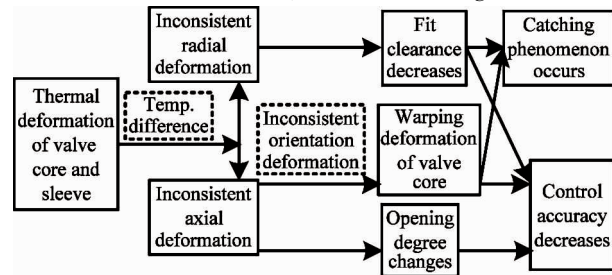

Fig. 4 Analysis of the catching phenomenon of valve core

2 Numerical simulation of valve core's clamping stagnation

Clamping stagnation of valve core is mainly caused by radial thermal deformation and warping deformation of valve core and valve sleeve, and it is the key fit clearance change of valve core and valve sleeve. Therefore, based on real extreme conditions of servo valve, three-dimensional flow-solid-thermal coupling situation of servo valve is simulated by ANSYS software and the change of key fit clearance between valve core and valve sleeve is quantitatively analyzed in Refs[16-18].

2.1 Boundary conditions for flow-solid-thermal numerical simulation

In order to simulate the extreme conditions of servo valve, it is assumed that the oil temperature of servo valve rises from 40 °C to 120 °C within 6 s during the process of theoretical analysis with an average temperature rise of 13.3 °C/s. The temperature loading curve is shown as Fig. 5.

The inlet and outlet of servo valve are set as pressure inlet and pressure outlet. The temperature of hy-

draulic oil at the entrance is shown as Fig. 5. The control flow channel and main flow channel are fluid zone, and shell, valve core and valve sleeve are solid zone. The contact between flow path and valve core, valve sleeve and shell are set to interface surface. The contact between valve core and valve sleeve, sleeve and shell is set to interface surface. The contact between shell and atmosphere is automatically set to natural heat dissipation surface according to respective material properties, as shown in Fig. 6.

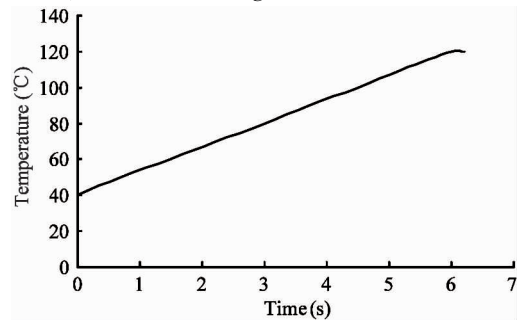
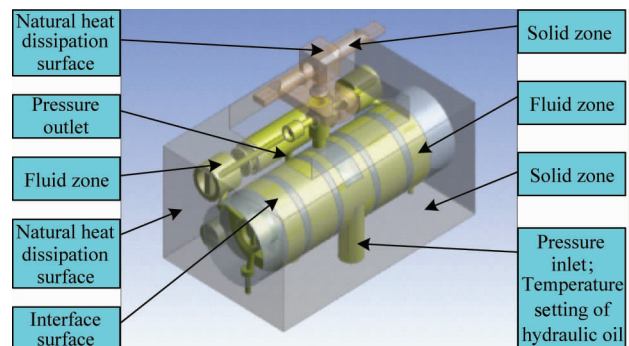
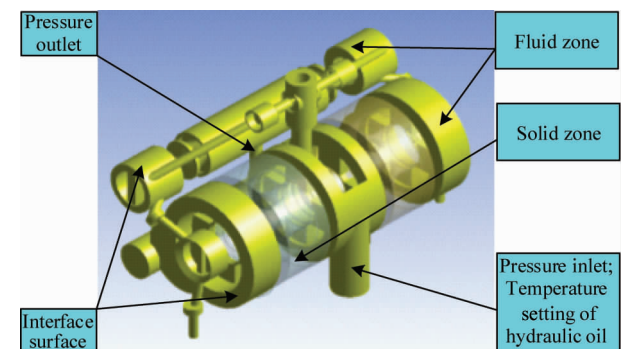

Fig. 5 Temperature loading curve of servo valve



(a) Servo valve analysis model



(b) Servo valve flow field analysis model

Fig. 6 Boundary conditions diagram

2.2 Thermal deformation of valve core and valve sleeve

The main flow path and control flow channel are unsymmetrical along circumference. And then it results in dramatic heat exchange, high temperature, greater thermal deformation at the top of valve core and valve

sleeve. Meanwhile, heat exchange is slow, temperature is very low, and then thermal deformation is very small at the bottom. The thermal deformation of valve core and valve sleeve decreases from top to bottom, as shown in Fig. 7 and Fig. 8.

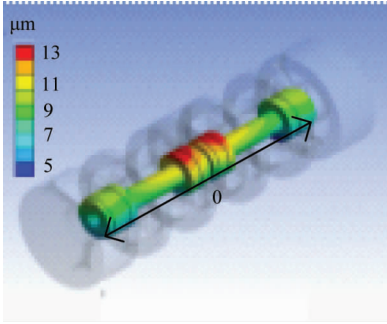

Fig. 7 Thermal deformation of valve core

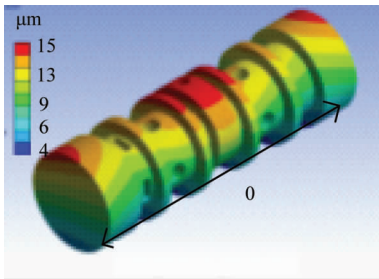

Fig. 8 Thermal deformation of valve sleeve

2.3 Effect of thermal deformation on key fit clearance of valve core and valve sleeve

Decreasing of key fit clearance between valve core and valve sleeve caused by the radial thermal deformation and warping deformation can lead to bad movement smoothness, and then catching phenomenon of the valve core occurs.

In order to analyze the change of the key fit clearance of valve core and valve sleeve quantitatively, eight straight lines (A-A, B-B . . . H-H) are selected on contact ring surface of valve core and valve sleeve, as shown in Fig. 9 and Table 2.

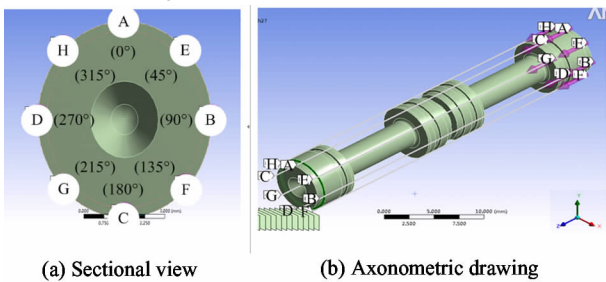

Fig. 9 Position of valve core data point

Table 2 Orientation of data collecting point

| Data collecting point | A | B | C | D | E | F | G | H |
|-----------------------|---|----|-----|-----|----|-----|-----|-----|
| Orientation (°) | 0 | 90 | 180 | 270 | 45 | 135 | 215 | 315 |

There are 8 pressure grooves between valve core and valve sleeve. The valve core and valve sleeve near the pressure grooves are separated. Thermal deformation of contact zone near 8 data lines can be analyzed, and the analysis zone is shown as the black line between two dashed lines in Fig. 10.

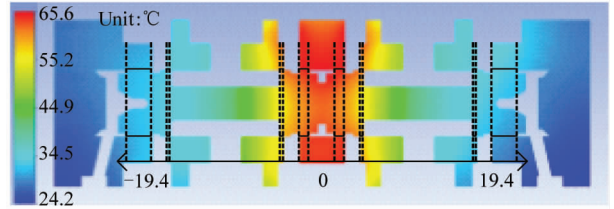

Fig. 10 Temperature contour of valve core and valve sleeve

The thermal deformation of valve core and valve sleeve in the same contact zone is inconsistent, the change of the key fit clearance can be characterized with the difference between the thermal deformation of valve sleeve and valve core. Positive value indicates that the thermal deformation of the valve sleeve is greater than that of the valve core, and then the fit clearance becomes larger. The negative value indicates that thermal deformation of the valve sleeve is smaller than that of the valve core, and then the fit clearance becomes smaller.

At 20 s, the relative deformation of several data points of valve sleeve and valve core are not equal as shown in Fig. 11. The relative deformation at 225 ° is 0.5 – 1.5 μm, meanwhile the relative deformation of other points is -0.5 – 0.5 μm. This phenomenon is caused by the axial asymmetry of flow channel and the uneven heat conduction of valve sleeve and valve core. The clearance fit between valve sleeve and valve core is usually 3 – 5 μm, and the deformation does not affect the normal operation of servo valve.

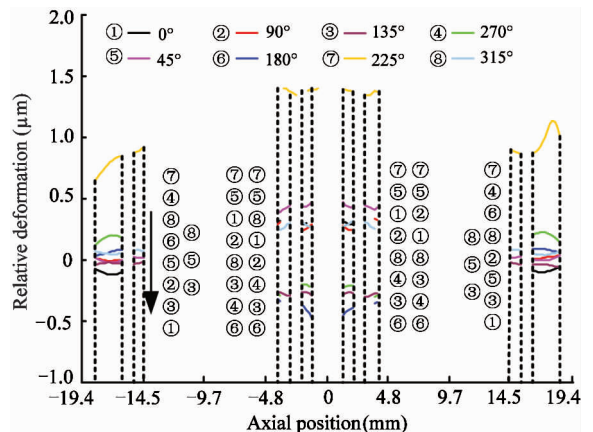

Fig. 11 Deformation of valve sleeve and valve core at 20 s

The relative deformation of middle part of valve core and valve sleeve is greater than two ends. Taking 225° azimuth data line as an example, the relative deformation of the middle part is 0.8 μm , which is greater than that of the two ends. Meanwhile the relative change of middle part is smaller than that of the two ends at other azimuth data lines. This phenomenon shows that the return port is located in the middle of valve core. The heat hydraulic oil flows out from return port, and then the thermal deformation of valve sleeve and valve core near the return port is greater. The bending deformation of valve core and valve sleeve is caused by the inconsistent of the relative thermal deformation of contact zone in same azimuth line at different axial position.

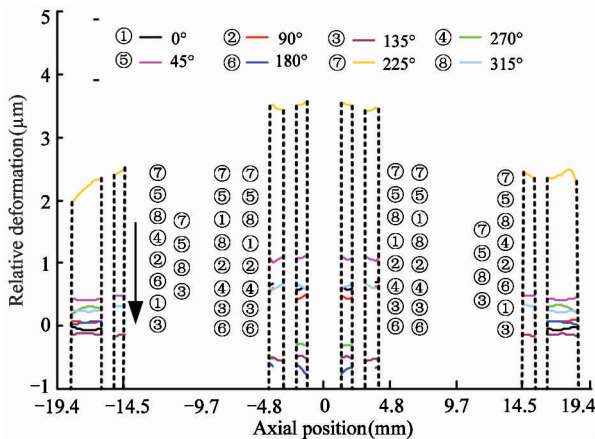

Fig. 12 Deformation of valve sleeve and valve core at 40 s

The relative deformation of key fit clearance between valve sleeve and valve core continues to expand at 60 s as shown in Fig. 13. The relative deformation at 225° is 3.7 – 6.0 μm , meanwhile the relative deformation at other azimuth points is $-2 - 2 \mu\text{m}$. After 60 s, the relative deformation of valve sleeve and valve core is larger than the fit clearance, and the warping deformation increases. The movement smoothness of valve core reduces, and then the catching phenomenon occurs.

According to quantitative analysis of thermal deformation, when oil temperature reaches 100 $^{\circ}\text{C}$, the relative deformation of valve sleeve and valve core is larger than the fit clearance, and the warping deformation increases. The movement smoothness of valve core reduces, and then the catching phenomenon occurs.

When designing the servo valve, the flow channel should be axially symmetric relative to valve sleeve and valve core, and then the fit clearance between valve sleeve and valve core can increase reasonably.

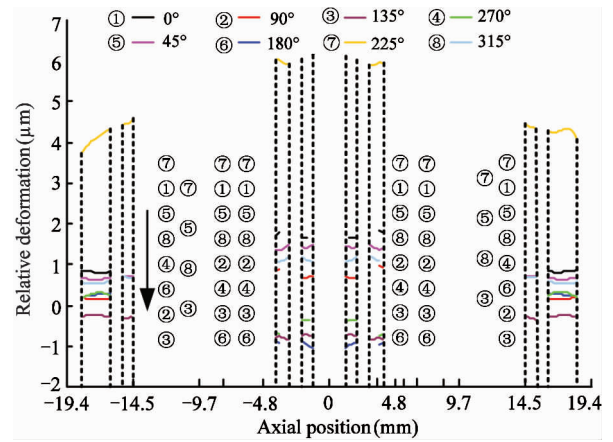

Fig. 13 Deformation of valve sleeve and valve core at 60 s

2.4 Effect of Thermal deformation on opening degree

The return port and feedback rod is in the middle of valve core, and the axial deformation are extended from center to two ends. The axial deformation at 0 mm is zero, and the axial deformation at two ends of valve sleeve and valve core is the largest. The effect of axial deformation on valve sleeve and valve core is mainly reflected in the change of the opening accuracy of the slide valve.

Axial deformation of valve sleeve and valve core at 20 s, 30 s, 40 s is shown as Fig. 14 – Fig. 16.

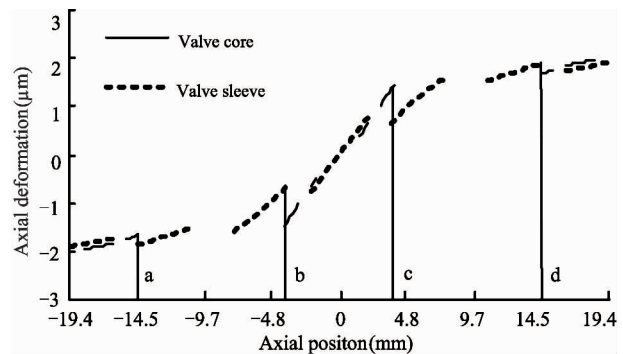

Fig. 14 Axial deformation of valve sleeve and valve core at 20 s

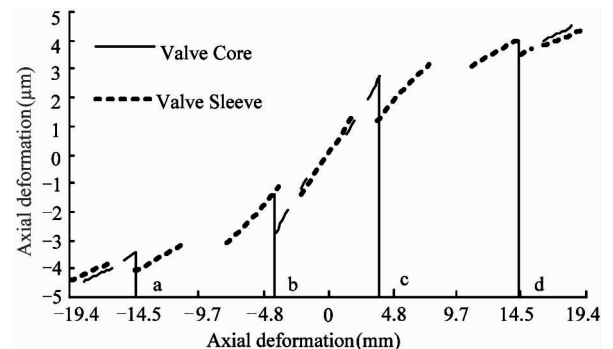

Fig. 15 Axial deformation of valve sleeve and valve core at 40 s

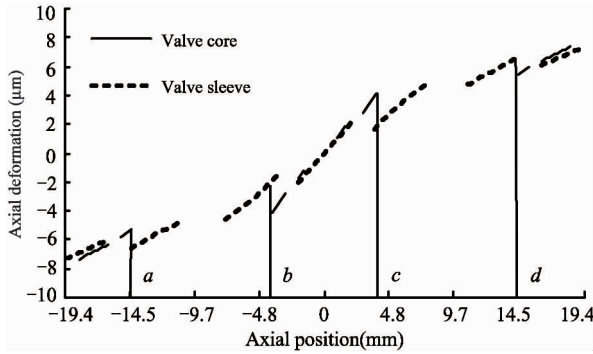

Fig. 16 Axial deformation of valve sleeve and valve core at 60 s

As time increases from 20 s to 60 s, the maximum axial deformation of valve sleeve and valve core increases from 2 μm to 7.2 μm as shown from Fig. 14 to Fig. 16.

The axial deformation of valve sleeve and valve core in different position is inconsistent. In Fig. 16, position a, b, c and d are opening positions of servo valve. The relative difference of thermal deformation between valve sleeve and valve core makes the greatest impact on the operation of servo valve.

The relative deformation between valve sleeve and valve core at position a and d at 20 s is 0.2 μm, and the relative deformation at position b and c is 0.8 μm. The relative deformation at position a and d at 40 s is 0.5 μm, and the relative deformation at position b and c is 1.3 μm. The relative deformation at position a and d at 60 s is 1.0 μm, and the relative deformation at position b and c is 2.0 μm.

Since the opening degree of servo valve is 18 – 350 μm, so under the working condition of high temperature and low opening degree, the axial deformation difference makes great impact on operation accuracy and stability of servo valve.

3 Experimental test of clamping stagnation of valve core

In order to verify the influence of thermal deformation on the working reliability of valve core, electrohydraulic servo valve static characteristic test bench of XX company is used to test servo valve XX-8/062-30#

and XX-19/101-15#. The system principle and experimental condition are shown in Fig. 17 and Table 3.

During the process of experiment, the temperature of hydraulic oil which flows into the inlet of servo valve increases from 40 °C to 120 °C, and the electrical current of servo valve is recorded by X-Y Recorder as Fig. 18 and Fig. 19.

As the temperature of hydraulic oil increases, the electrical current of XX-8/062-30# changes at 80 °C. The amplitude of current is stable before 80 °C. Meanwhile it begins to increase after 80 °C, and the burr phenomenon occurs. The amplitude and burr of current gradually increase as Fig. 18.

Similarly, when the oil temperature reaches 90 °C, electrical current of XX-19/101-15# appears following the same trend as Fig. 19.

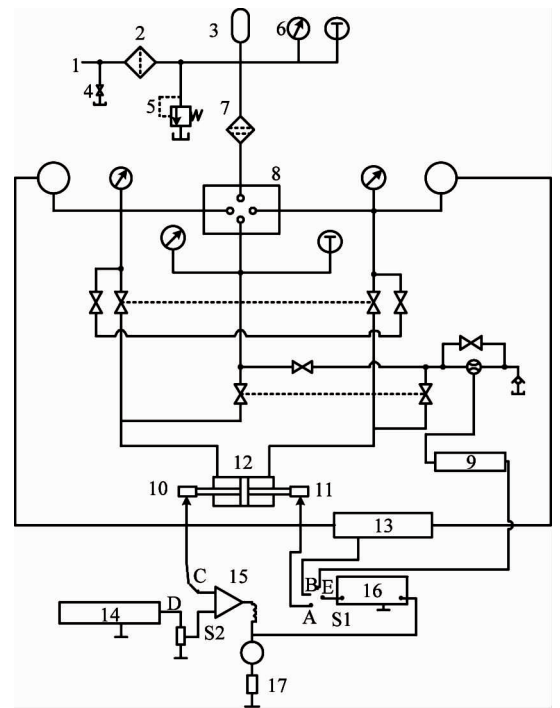

Fig. 17 Principle of electrohydraulic servo valve temperature screening test bench

Table 3 Experimental Condition

| Parameter | Environment temperature | Supply pressure | Relative humidity | Cleanliness grade of oil | Hydraulic oil |
|-----------|-------------------------|-----------------|-------------------|--------------------------|---------------|
| Value | 20 ± 5 °C | 20 MPa | ≤ 80% | 13/11 | 10# |

Due to thermal deformation difference of valve sleeve and valve core, the key fit clearance is gradually

reduced, and then original relationship of valve sleeve and valve core has changed. The movement smoothness

of valve core is blocked, and the catching phenomenon appears. The amplitude of electrical current of servo valve gradually increases, and then burr phenomenon occurs.

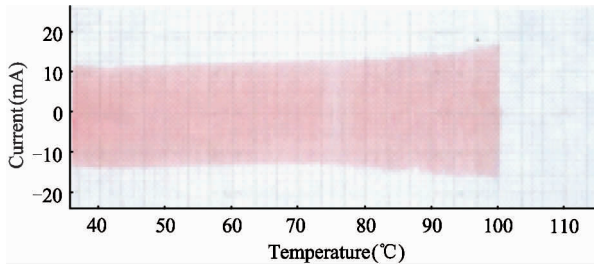

Fig. 18 Electrical current of servo valve XX-8/062-30#

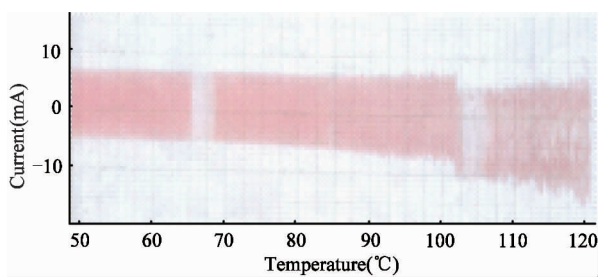

Fig. 19 Electrical current of servo valve XX-19/101-15#

In order to improve the phenomenon of clamping stagnation, the valve core of XX-8/062-30# and XX-19/101-15# is re-grounded. The movement smoothness of valve core is tested, and the electrical current is shown as Fig. 20 and Fig. 21.

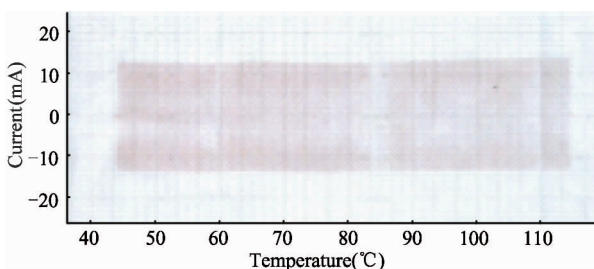

Fig. 20 Electrical current of servo valve XX-8/062-30# after grinding

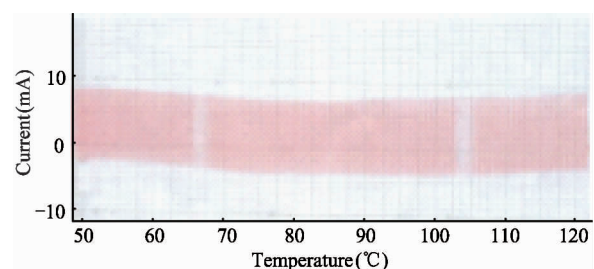

Fig. 21 Electrical current of servo valve XX-19/101-15# after grinding

The electrical current of servo valve after re-grinding becomes smooth and uniform. As oil temperature rises, the amplitude of the electrical current remains basically unchanged. And there is no burr phenomenon as Fig. 20 and Fig. 21.

Therefore, the thermal deformation of valve core and valve sleeve caused by change of oil temperature makes the fit clearance no longer equal to the initial value. Clamping stagnation and catching phenomenon of valve core appears, and then the servo valve failure happens. After the thermal test, the fit clearance of valve sleeve and valve core after re-grinding can work smoothly, and the clamping stagnation and catching phenomenon disappears. As the fluid temperature increases, the valve core and valve sleeve will be thermally expanded, resulting in the gap between valve core and valve sleeve no longer equal to the initial value, and the valve core movement blocked, the movement reliability decreases. Re-grinding the valve core at a high temperature so as to cancel out the portion of the valve core and valve sleeve which expands due to heat. So that the gap between the valve core and valve sleeve backs to the initial state, and then the operating reliability of servo valve greatly increases.

4 Conclusion

As oil temperature increases, relative deformation between valve sleeve and valve core is not consistent in different directions at the same section, and the fit clearance is no longer equal to the initial value. The relative deformation is not consistent in the same direction at different axial position, and the deformation in the middle part is bigger than that of the two ends, and then the warp deformation of valve sleeve and valve core appears.

When the oil temperature is high, relative deformation of valve sleeve and valve core is large. The motion smoothness of the valve core is obstructed, and the clamping stagnation and catching phenomenon appears. So the flow channel should be axial symmetrical distribution along the axis of the valve core, and the fit clearance between valve core and valve sleeve can increase reasonably.

The deformation difference between valve sleeve and valve core at different axial positions can impact the opening accuracy of servo valve. Especially at high temperature and small opening conditions, the work accuracy and stability of the servo valve can be greatly affected.

References

- [1] Pham X H S, Tran T P. Mathematical model of steady state operation in jet pipe electro-hydraulic servo valve [J]. *Journal of Donghua University (English Edition)*, 2013, 30(4): 269-275
- [2] Karunanidhi S, Singaperumal M. Design, analysis and simulation of magnetostrictive actuator and its application to high dynamic servo valve[J]. *Sensors and Actuators, A: Physical*, 2010, 157(2): 185-197
- [3] Liu Y L. Simulation and Analysis of Flow Field of $\Phi 8$ Path Servo Valve Slip Valve[D]. Qinhuangdao: Yanshan University, 2012(In Chinese)
- [4] Halder M R, Dash S K, Som S K. Initiation of air core in a simplex nozzle and the effects of operating and geometrical parameters on its shape and size[J]. *Experimental Thermal and Fluid Science*, 2002, 26(8): 871-878
- [5] Sirouspour M R, Salcudean S E. On the nonlinear control of hydraulic servo-systems [C]. In: Proceedings of the IEEE International Conference on Robotics and Automation, San Francisco, USA, 2000. 1276-1282
- [6] Krivts I L. Optimization of performance characteristics of electro-pneumatic (two-stage) servo valve [J]. *Journal of Dynamic Systems, Measurement and Control, Transactions of the ASME*, 2004, 126(2): 416-420
- [7] Zhang K, Yao J Y. Degradation assessment and life prediction of electro-hydraulic servo valve under erosion wear [J]. *Engineering Failure Analysis*, 2014 (1): 284-300
- [8] Zhang L, Luo J. Research on electro hydraulic proportional control for heavy vehicle blend braking system[J]. *Journal of China Ordnance*, 2009 (1): 6-10
- [9] Gao D R, Lu X H. Calculation and analysis of internal flow field of a double nozzle flapper valve of two-stage electro-hydraulic servo valve[J]. *China Mechanical Engineering*, 2012, 23(16): 1951-1956(In Chinese)
- [10] Yin Y B, Huang W D, Zhang X. On the flow field of nozzle flapper valve of electro-hydraulic servo valve[J]. *Fluid Power Transmission and Control*, 2011 (3): 1-4
- [11] Yun X, Cheng X F, Jin Y L, et al. Numerical simulation and experimental study of the nozzle flapper electro-pneumatic pressure servo valve based on fluent[J]. *Hydraulics Pneumatics and Seals*, 2013 (9): 10-13
- [12] Beune A, Kuerten J G M, Van H M P C. CFD analysis with fluid-structure interaction of opening high-pressure safety valves[J]. *Computers and Fluids*, 2012, 64(15): 108-116
- [13] Wang X L, Zhu Y C, Cheng Q F, et al. Simulation research on the four-nozzle flapper valve based on GMA [C]. In: Proceedings of the 2011 International Conference on Advanced Engineering Materials and Technology, Sanya, China, 2011. 239-244
- [14] Zhang L, Luo J, Yuan R B, et al. The CFD analysis of twin flapper-nozzle valve in pure water hydraulic [J]. *Procedia Engineering*, 2012 (31): 220-227
- [15] Peng Z F, Sun C G, Yuan R B, et al. The CFD analysis of main valve flow field and structural optimization for double-nozzle flapper servo valve[J]. *Procedia Engineering*, 2012, (31): 115-121
- [16] Tang J, Gao D R, Wang L W. Research on influence of parameters variation on the fixed orifice performance of the servo valve[C]. In: Proceedings of the 2011 International Conference on Mechatronics and Applied Mechanics, Hong Kong, China, 2011. 612-616
- [17] Zhao J H, Liang Y N, Gao D R. Oil pocket's bearing capacity analysis of liquid hydrostatic worktable in gentry moving milling center[J]. *Chinese Journal of Mechanical Engineering*, 2014, 27(5): 1008-1017
- [18] Zhao J H, Zhou S L, Lu X H, et al. Numerical Simulation and experimental study of heat-fluid-solid coupling of double flapper-nozzle servo valve[J]. *Chinese Journal of Mechanical Engineering*, 2015, 28(5): 1030-1038

Zhao Jianhua, born in 1983. He is an associate professor of School of Mechanical Engineering, Yanshan University, P. R. China. He received his Ph. D degree from Yanshan University in 2013. He received his bachelor degree in 2006, master degree in 2010, from School of Mechanical Engineering, Yanshan University. His research interests include the simulation and analysis of hydrostatic bearing.